

SERENITY Air Baths MODEL # AI27AIRCOPPER / AI27COPPERTO (Tub Only)

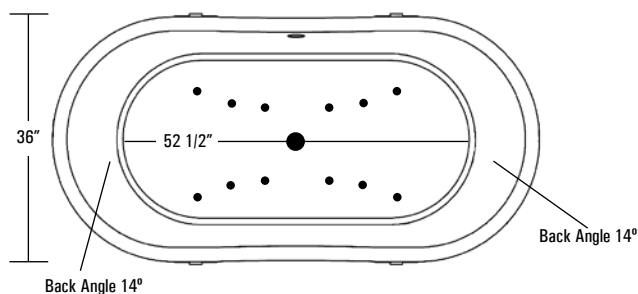

Note: This model requires a remote blower location. The connection for the air blower is under the tub. Please refer to the Owner's Manual for detailed installation instructions. Document #1172 on our Fax-on Demand System or on our website at www.aquaticwhirlpools.com.

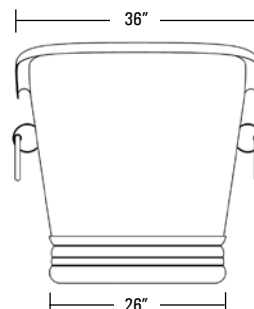
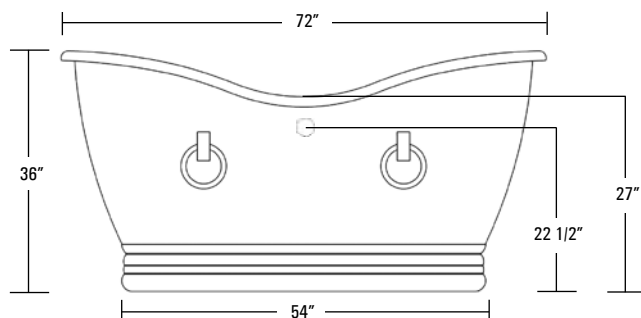

Rough-In Plumbing Measurements

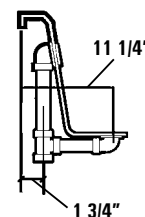

Note: This model can be ordered with or without decorative rings.

SPECIFICATIONS:

GENERAL SPECIFICATIONS:

Tub Size	72" x 36" x 36"
	183 cm x 91 cm x 91 cm
Bathing Well	52 1/2" long
	25" wide
	22" interior depth
Maximum Water Depth	16 3/4"
Shipping Weight	451 lbs. / 205 kg
Tub Weight Filled	1181 lbs. / 515 kg
Tub Only Weight	185 lbs. / 84 kg
Gallons to Overflow	120 gal. / 454 L

ELECTRICAL SPECIFICATIONS:

Blower/Heater	1 HP; 10.5 AMP; 120V
Requirement	15 AMP; 120V, separate circuit required protected w/ Class A GFCI

STANDARD EQUIPMENT:

- Air Bath System:**
- 1 HP Variable Speed Remote Air Blower with 20-Minute Timer
 - 600 Watt Air Heating System
 - Electronic Control Package with Wave and Pulse Features
 - Automatic Purge and Dry Cycle
 - Waterproof Remote Control with Infrared Sensor and 25' Cord
 - Waste and Overflow in Oil Rubbed Bronze
- Aquatic Quality Features:**
- Extra Deep and Long Bathing Well
- UL & IAPMO Listed, Factory Tested**
Limited Lifetime Warranty

OPTIONAL EQUIPMENT:

- This model can be ordered with or without decorative rings.

Each Serenity 27 bath is handcrafted out of copper. Please note that the hammered copper with a weathered finish will vary from model to model and may gradually change with time due to copper's unique character.

Fax-On-Demand Document # 1007



Each Serenity Air Bath model is equipped with a 600 watt air heating system to raise the temperature of the air going into the bath. This air temperature will be less than the bathing temperature of the water, but will help to reduce a rapid decrease in water temperature. In addition, the air coming from the air jets will feel cool against the skin, just as a breeze on a warm day cools your body. This system does not heat the water.

The manufacturer accepts a 1/4" variance. There are variations on each tub and specifications are subject to change as we improve upon our product as required. The dimensions needed for site preparation and structure building should be measured from the tub; Aquatic Industries, Inc. assumes no responsibility for preparatory work. www.aquaticwhirlpools.com 800.555.5324