

CENTURY 27

AQUATIC

CENTURY SERIES MODEL # AI7242RC27

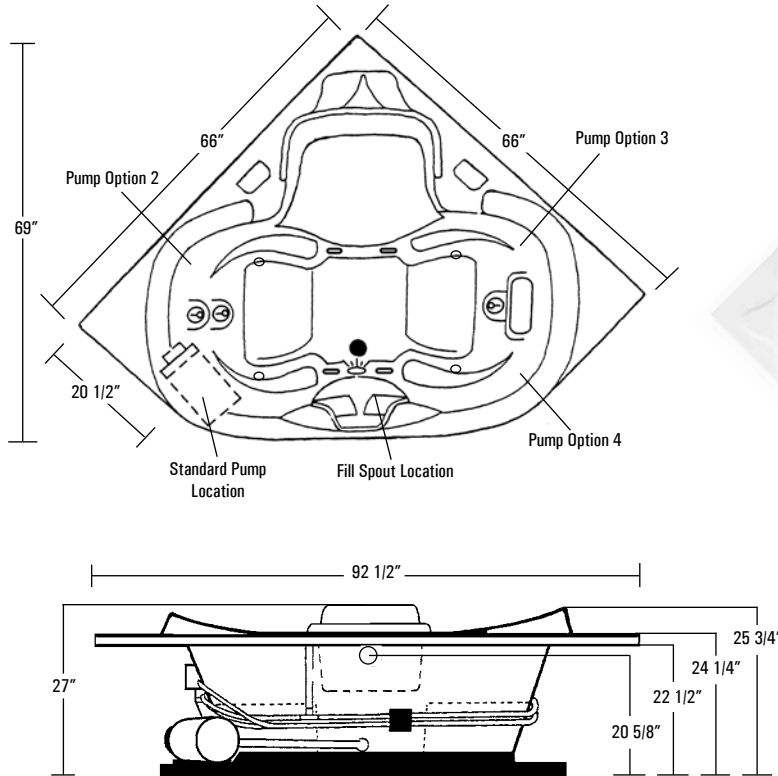

*Available without fast-fill waterfall spout.



Rough-In Plumbing Measurements

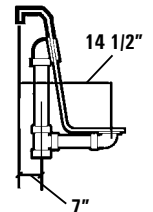

SPECIFICATIONS:

GENERAL SPECIFICATIONS:

Tub Size	66" x 66" x 27" 168 cm x 168 cm x 69 cm
Bathing Well	43" long 22 1/2" wide 23 1/4" interior depth
Shipping Weight	324 lbs. / 147 kg
Tub Weight Filled	997 lbs. / 452 kg
Gallons to Overflow	95 gal. / 360 L
Gallons to Operate	1 bather: 76 gal. / 288 L 2 bathers: 57 gal. / 216 L

ELECTRICAL SPECIFICATIONS:

Pump Requirement	2 HP; 11 AMP; 110V 15 AMP; 110V, separate circuit required protected w/ Class A GFCI
Inline Heater Requirement	1.5 kW; 12 AMP; 110V 15 AMP; 110V, separate circuit required protected w/ Class A GFCI

This unit is not recommended for shower installations.

This unit has a 3/4" female waterfall fill spout connection.

STANDARD EQUIPMENT:

- 12 Hydrotherapy Jets including:**
- 4 Full Size Pressure-Flo Hydrotherapy Jets
 - 4 Pressure Plus Hydrotherapy Jets
 - 3 Recessed Rotary Massage Jets
 - 1 Recessed Fan Jet
- Aquatic Quality Features:**
- 2 HP, 3-Speed Run-Dry Pump
 - Bath-Side Electronic Control Panel
 - Integrally Molded Fast-Fill Waterfall Spout/Optional - please specify on order (valves not included)
 - Chromatherapy
 - 1.5 kW Inline Maintenance Heater
 - "Quiet Pad" Anti-Vibration Pump Mount for Quiet Pump Operation
 - 2 Extra Deep & Wide Contoured Lounge Seats
 - 4 Arm Rests
 - Slip Resistant Floor
 - Pre-leveled ABS Support Base
 - Heat-bent Rigid PVC Piping for Optimum Sanitary Conditions
 - Durable, Easy to Clean, Lucite® Cast Acrylic Surface
 - Available in 8 Standard No-Charge Colors
- UL & IAPMO Listed, Factory Tested Limited Lifetime Warranty**

OPTIONAL EQUIPMENT:

- Available without Fast-Fill Waterfall Spout -- See Price List for Details
- Comfort Pillow -- Oval or Rectangle
- Jet Finish
 - Chrome, Polished Brass, Gold, Polished Nickel or Satin Nickel
- Lift & Turn Waste and Overflow
 - Chrome, Polished Brass, Gold, Polished Nickel, Satin Nickel or Oil Rubbed Bronze
- Cable Drive Waste and Overflow
 - Chrome, Polished Brass, Gold, Polished Nickel, Satin Nickel, Oil Rubbed Bronze or Color Matched (Bone, White and Biscuit Only)
- Hand Held Jet - Chrome or Polished Brass
- Factory Installed Rigid ABS Tile Flange
- Optional Pump Location
- Remote Pump Location
- Color Matched Curved Acrylic Skirt
- Premium Colors

All acrylic colors featured by Aquatic match the industry's leading fixture manufacturers.

Fax-On-Demand Document # 1012



The manufacturer accepts a 1/4" variance. There are variations on each tub and specifications are subject to change as we improve upon our product as required. The dimensions needed for site preparation and structure building should be measured from the tub; Aquatic Industries, Inc. assumes no responsibility for preparatory work. www.aquaticwhirlpools.com 800.555.5324